

# DIAMONDS AND GEMSTONES

---

45 The Anatomy of a Diamond

45 Ideal Cut

46 The 4 Cs

48 Stone Shapes

50 Stone Cuts

52 Diamond Size Chart



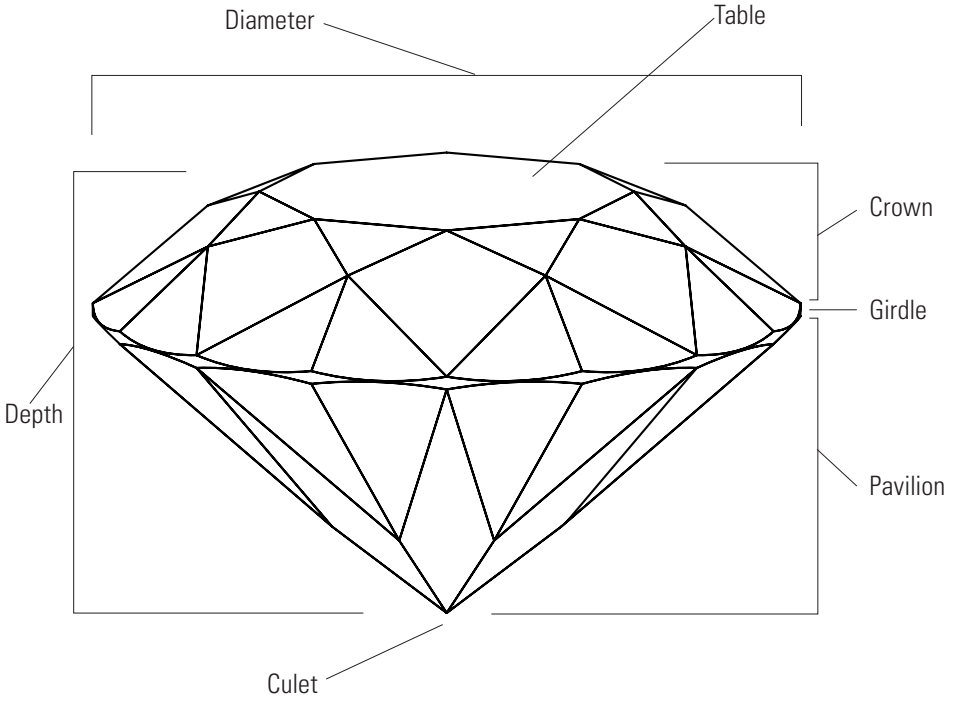

AMERICAN GEMOLOGICAL SOCIETY (AGS®)  
IDEAL CUT

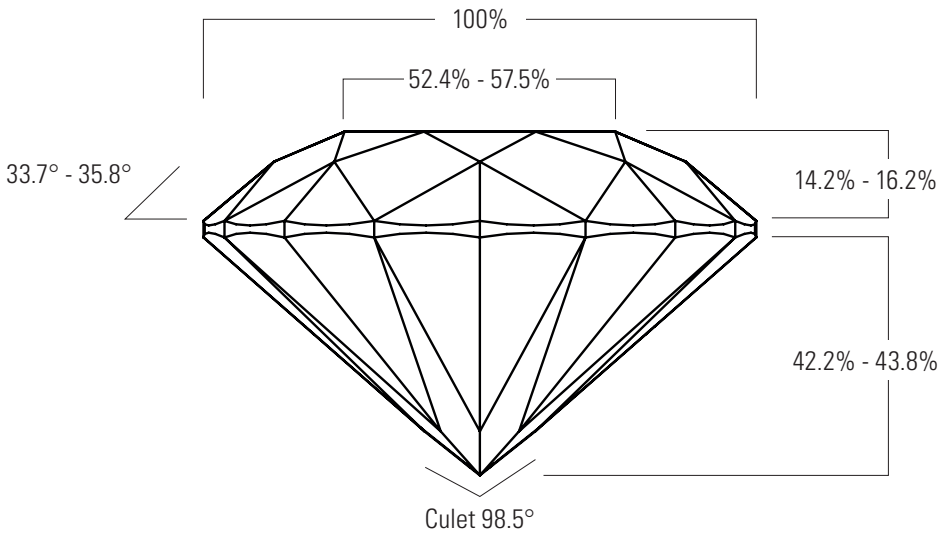

GEMOLOGICAL INSTITUTE OF AMERICA (GIA®)  
DIAMOND GRADING

**COLOR**

One factor that determines the value of a diamond is its color. With the exception of fancy-colored diamonds, the most valuable diamonds are those with the least color. Although many people think of gem quality diamonds as colorless, completely colorless diamonds are very rare. The diamond color scale ranges from D (colorless) to Z (light yellow or brown). A diamond's color is determined by a manual process of comparing the diamond to a master set. Each letter grade represents a range of color and is a measurement of how noticeable a color is.

When diamonds are formed with traces of other minerals, rare and beautiful colors can result. These "fancy" colors range from blue and brilliant yellow to red, brown, pale green, pink, and violet. Because of their rarity, colored diamonds are highly desirable and typically more valuable.

Color Grading Scale

D E F	G H I J	K L M	N O P Q R	S T U V W X Y	Z+
colorless	nearly colorless	faint yellow	very light yellow	light yellow	fancy

**CLARITY**

A diamond's clarity is measured by the existence or absence of visible flaws. Tiny surface blemishes or internal inclusions, even those seen only under magnification, can alter the brilliance of the diamond and thus affect its value. Clarity levels begin with flawless (FL, IF), followed by very, very slight (VVS<sub>1</sub>, VVS<sub>2</sub>), very slight (VS<sub>1</sub>, VS<sub>2</sub>), slightly included (SI<sub>1</sub>, SI<sub>2</sub>), and included (I<sub>1</sub>, I<sub>2</sub>, and I<sub>3</sub>).

Clarity Grading Scale

FL	VVS <sub>1</sub>	VVS <sub>2</sub>	VS <sub>1</sub>	VS <sub>2</sub>	SI <sub>1</sub>	SI <sub>2</sub>	I <sub>1</sub>	I <sub>2</sub>	I <sub>3</sub>
flawless no blemishes	very, very slightly included		very slightly included		slightly included		imperfect, eye visible		

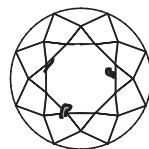
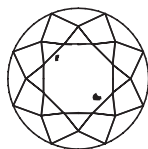
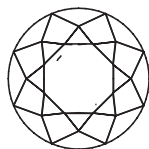
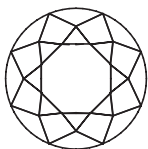

| visible under magnification only | | eye visible |

## CUT

While cut does include shape, in terms of the 4 Cs it refers to the proportions of the cut. A diamond's cut grade is an objective measure of a diamond's light performance, or the amount of sparkle a diamond has.

A diamond's overall proportions, as well as the size and position of its facets, make up the cut. The consistency and balance of these can greatly affect how the stone captures light and reflects it back to the eye. When a diamond is cut with the proper proportions, light enters the diamond and is returned through the top of the diamond. If a diamond is too shallow, light will escape from the bottom of the stone. If it is cut too deep, light will escape out the sides.

Studies have been conducted to find the optimum proportions of a diamond's cut so that it has the greatest amount of sparkle. If its cut falls within these parameters, it is considered an ideal cut. Diamonds with fine proportions, symmetry and polish optimize their interaction with light and have increased brilliance, dispersion, and scintillation.

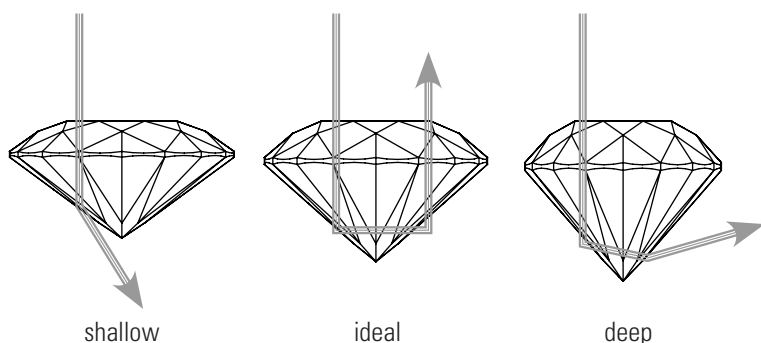

## CARAT

Carat refers to a diamond's weight. One carat, the traditional unit of measurement for diamonds, is approximately 0.2 grams. You may also hear the weight of a diamond referred to in points. One carat is equivalent to 100 points, so a 75-point diamond is equal to 0.75 carats. Because they are rarer, larger diamonds have greater value per carat, so the price of a diamond rises exponentially to its size. (Refer to diamond size chart, page 52).

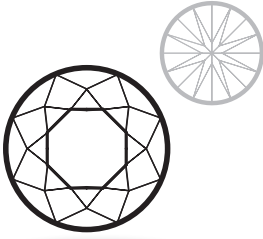

Round

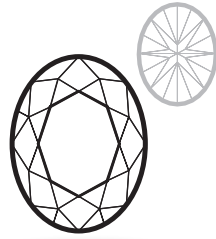

Oval

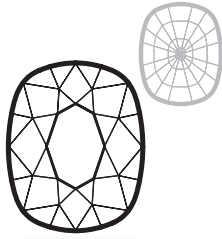

Cushion

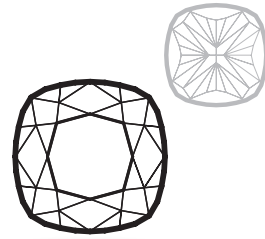

Square Cushion

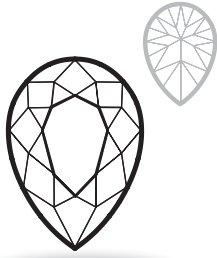

Pear

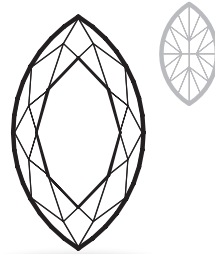

Marquise

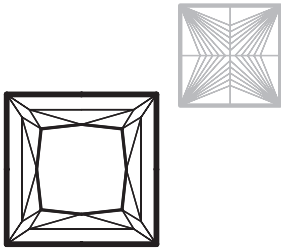

Square/Princess

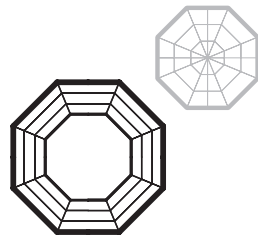

Octagonal

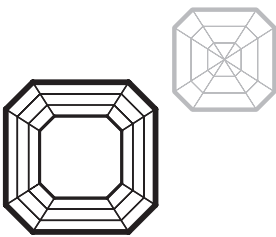

Asscher/Square Emerald

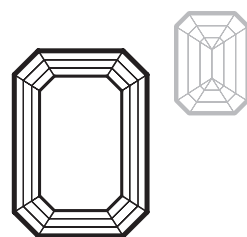

Emerald

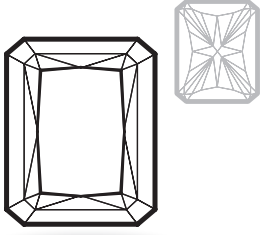

Radiant

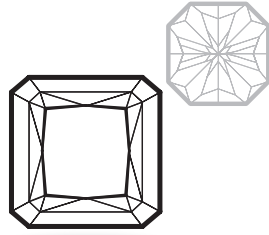

Square Radiant

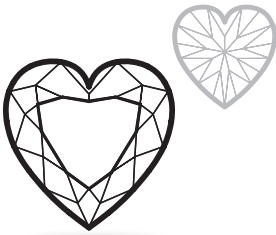

Heart

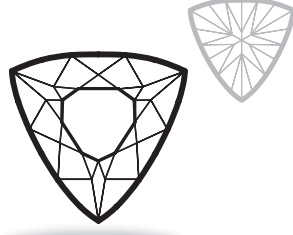

Trilliant/Trillion

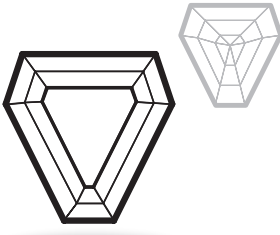

Shield/Calf

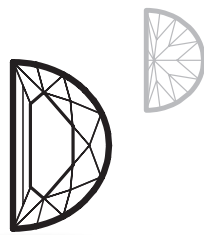

Half-Moon

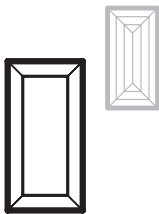

Straight Baguette

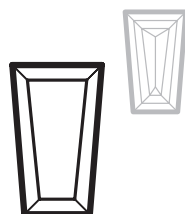

Tapered Baguette

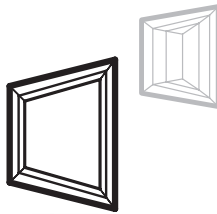

Trapezoid

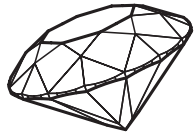

Brilliant



Side



Crown



Pavilion



Old European



Side



Crown



Pavilion



Old Mine



Side



Crown



Pavilion

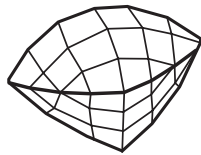

Checkerboard



Side

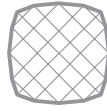

Crown

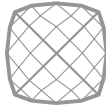

Pavilion



Table



Crown

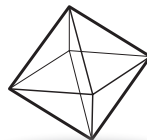

Point



Crown

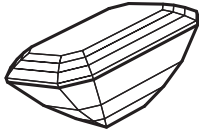

Step



Side



Crown



Pavilion

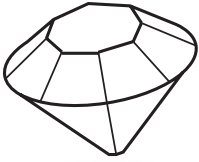

Eight



Side



Crown



Pavilion

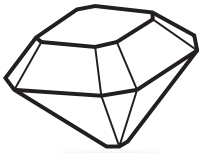

Old Single



Side



Crown



Pavilion



Rose



Crown



Briolette



Crown



Cabochon



Crown



Bullet





































































Crown













































































Master gem cutters, mathematicians, scientists, and jewelers have been developing unique and proprietary cuts to draw the beauty out of gemstone material. Some gem cuts are created to maximize the sparkle, while other gem cuts are created to draw the viewer into the gemstone.

# DIAMOND SIZE CHART

Diamonds illustrated to scale

carat weight	1/4	1/2	3/4	1.00	1 1/4	1 1/2
<b>ROUND</b>						
mm:	4.1	5.2	5.9	6.5	7.0	7.4
<b>SQUARE</b>						
mm:	3.0	4.35	4.95	5.5	6.0	6.5
<b>OVAL</b>						
mm:	5x3	6x4	6.5x4.5	7x5	7.5x5.5	8x6
<b>MARQUISE</b>						
mm:	6x3	8x4	9x4.5	10x5	10.5x5.25	11x5.5
<b>PEAR</b>						
mm:	5x3	6x4	7x5	8x5	8.5x5.5	9x6
<b>CUSHION</b>						
mm:	3.4	4.35	4.95	5.5	6.0	6.5
<b>EMERALD</b>						
mm:	5x3	6x4	6.5x4.5	7x5	7.5x5.5	8x6
<b>ASSCHER</b>						
mm:	3.4	4.35	4.95	5.5	6.0	6.5
<b>RADIANT</b>						
mm:	3.9	4.9	5.6	6.2	6.65	7.0
<b>TRILLIANT</b>						
mm:	4.0	5.0	5.75	6.5	6.75	7.0
<b>HEART</b>						
	3.9	4.9	5.6	6.2	6.65	7.0

Diamonds illustrated to scale

carat weight	1¾	2.00	2¼	2½	2¾	3.00	4.00
<b>ROUND</b>							
mm:	7.8	8.2	8.6	8.8	9.1	9.4	10.4
<b>SQUARE</b>							
mm:	7.0	7.5	7.75	8.0	8.15	8.3	9.0
<b>OVAL</b>							
mm:	8.25x6.25	8.5x6.5	8.75x6.75	9x7	9.5x7.5	10x8	11x9
<b>MARQUISE</b>							
mm:	11.5x5.75	12x6	12.5x6.25	13x6.5	13.5x6.75	14x7	16x8
<b>PEAR</b>							
mm:	9.5x6.5	10x7	10.5x7.25	11x7.5	11.5x7.75	12x8	14x9
<b>CUSHION</b>							
mm:	7.0	7.5	7.75	8.0	8.15	8.3	9.0
<b>EMERALD</b>							
mm:	8.25x6.25	8.5x6.5	8.75x6.75	9x7	9.5x7.5	10x8	11x9
<b>ASSCHER</b>							
mm:	7.0	7.5	7.75	8.0	8.15	8.3	9.0
<b>RADIANT</b>							
mm:	7.4	7.8	8.1	8.35	8.65	8.9	9.9
<b>TRILLIANT</b>							
mm:	7.5	8.0	8.25	8.5	8.75	9.0	10.0
<b>HEART</b>							
	7.4	7.8	8.1	8.35	8.65	8.9	9.9